

# Squire stainless Water heaters

## Installation, commissioning, and maintenance instructions



Models:  
SIT600-3000  
SDT600-3000



**Warning:**

Read and fully understand this manual before attempting to install this Water heater. It can cause personal injury and damage to the Water heater when you do not read the manual and/or do not obey the instructions.



**Lochinvar**<sup>®</sup>

info@lochinvar.ltd.uk  
**lochinvar.ltd.uk**

	<b>Document Control</b>			
<b>Article</b>	<b>Language</b>	<b>Version</b>	<b>Date</b>	<b>Modified by</b>
Squire stainless Installation Instructions	English	V1	20-May-24	S.Addis

# Contents

1.0	INTRODUCTION .....	3
1.1	GENERAL DESCRIPTION OF SAFETY SYMBOLS USED .....	3
1.2	ANCILLARY OPTIONS .....	3
2.0	SAFETY GUIDELINES .....	4
2.1	DIMENSIONAL DRAWINGS .....	5
3.0	GENERAL REQUIREMENTS .....	7
3.1	RELATED DOCUMENTS .....	7
4.0	WATER QUALITY .....	7
5.0	WATER CONNECTIONS .....	8
5.1	GENERAL .....	8
5.2	UN-VENTED SYSTEM .....	8
5.3	DE-STRATIFICATION .....	13
6.0	COMMISSIONING AND TESTING .....	13
6.1	ELECTRICAL INSTALLATION .....	13
6.2	WATER CONNECTION .....	13
6.3	PRIMARY HEAT SOURCE .....	13
7.0	MAINTENANCE .....	14
7.1	GENERAL .....	14
7.2	DRAINING THE WATER SYSTEM .....	14
7.3	RE-FILLING THE SYSTEM .....	14
7.4	OTHER CHECKS .....	14
8.0	USER INSTRUCTIONS .....	15
9.0	WARRANTY .....	15
10.0	APPENDIX 1 TECHNICAL DATA TABLES SIT600-3000 .....	16
11.0	APPENDIX 2 TECHNICAL DATA TABLES SDT600-3000 .....	17
12.0	APPENDIX 3 ErP SPECIFICATION DATA SHEETS .....	18

## 1.0 INTRODUCTION

Lochinvar Squire stainless steel vessels are designed to be used as an indirect vessel in conjunction with a solar thermal system or with a circulating condensing Boiler.



**These water heaters are not suitable for direct connection to an air source heat pump, contact Lochinvar for alternative solutions.**

There are two versions of the storage vessels.

The SIT range are stainless steel vessels suitable for systems with a maximum working pressure of up to 6 bar featuring a single indirect coil and a single immersion heater boss.

The SDT range of stainless steel vessels are suitable for systems with a maximum working pressure of up to 6 bar featuring two coils. The lower coil is suitable for a Solar Thermal System or other LZC technology, to be used in conjunction with a boiler. There is also the option of utilising both coils with a single boiler to achieve high recovery rates.

### 1.1 GENERAL DESCRIPTION OF SAFETY SYMBOLS USED



#### **BANNED**

**A black symbol inside a red circle with a red diagonal indicates an action that should not be performed**



#### **WARNING**

**A black symbol added to a yellow triangle with black edges indicates danger**



#### **ACTION REQUIRED**

**A white symbol inserted in a blue circle indicates an action that must be taken to avoid risk**

Lochinvar Squire stainless steel vessels are fitted with sensor pockets for monitoring the temperature via the solar control and/or BMS. Each vessel is also equipped with a 240v manual re-set overheat thermostat and a suitably sized unvented kit can be supplied as an ancillary if required.

- All installations must conform to the relevant Building Regulations. Health & Safety requirements must also be taken into account when installing any equipment. Failure to comply with the above may lead to prosecution.
- If the equipment is to be connected to an unvented (pressurised) system, care must be taken to ensure all extra safety requirements are satisfied should a high or low-pressure condition occur in the system.

### 1.2 ANCILLARY OPTIONS

- |                                 |                               |
|---------------------------------|-------------------------------|
| • De-Stratification Kit         | WH9                           |
| • Unvented kit                  | Contact Lochinvar for details |
| • 6kW 230v Immersion heater 15" | CSI107                        |
| • 9kW 415v Immersion heater 16" | CSI111                        |
| • 9kW 415v Immersion heater 21" | CSI112                        |

## 2.0 SAFETY GUIDELINES

### **Carefully read all the instructions before commencing installation.**

Keep these instructions near the water heater for quick reference.

This equipment must be installed by a competent person. All installations must conform to the relevant Building Regulations. Health & Safety requirements must also be considered when installing any equipment. Failure to comply with the above may lead to prosecution.

Commissioning, maintenance, and repair must be done by a skilled installer/engineer, according to all applicable standards and regulations.



**Lochinvar Limited is not liable for any damage caused by inaccurately following these mounting instructions. Only original parts may be used when carrying out any repair or service work.**



**This appliance is not intended for use by persons (including children) with reduced physical, sensory, or mental capabilities, or lack of experience and knowledge, unless they have been given supervision or instruction concerning use of the appliance by a person responsible for their safety. Children should be supervised to ensure that they do not play with the appliance.**

## 2.1 DIMENSIONAL DRAWINGS

### 2.1.1 SIT600-3000

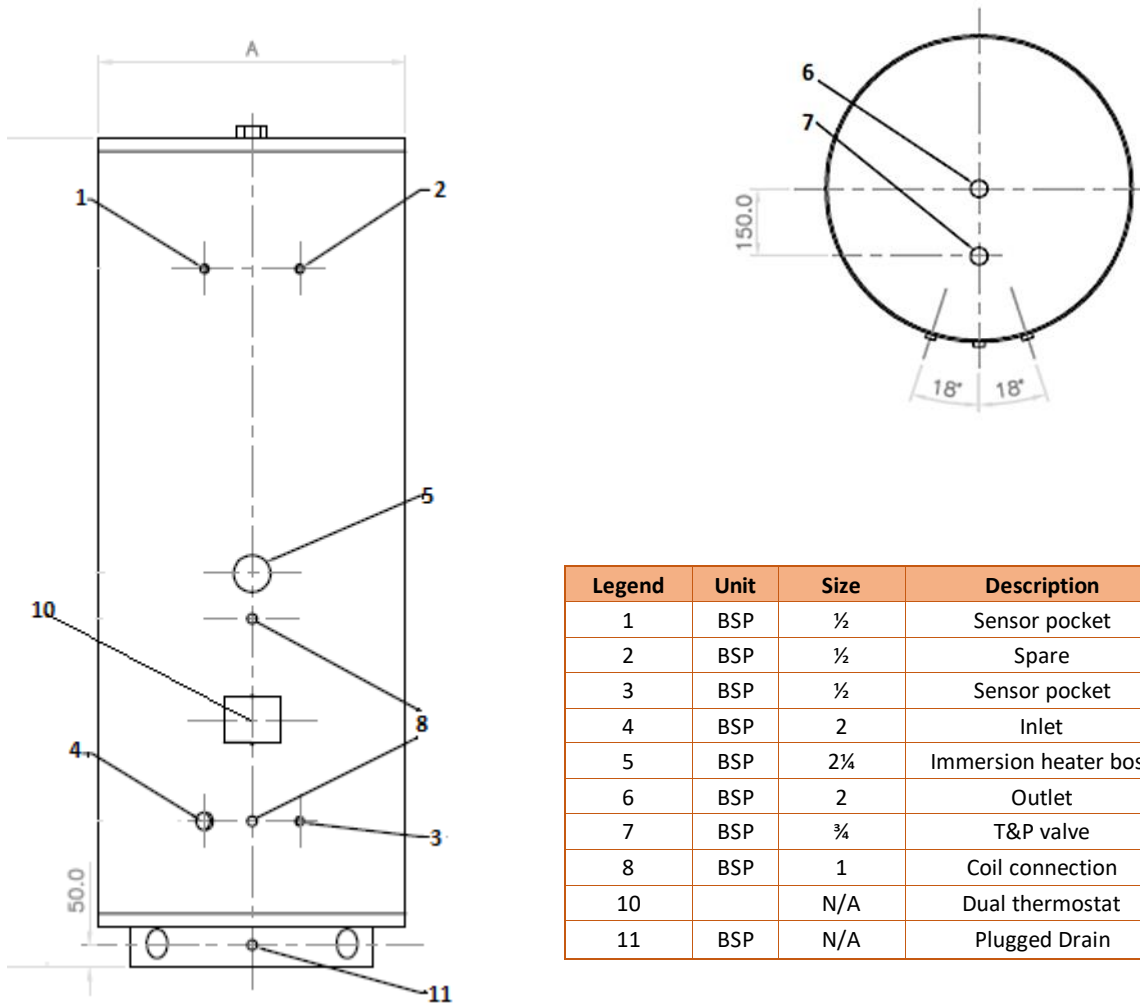

Legend	Unit	Size	Description
1	BSP	½	Sensor pocket
2	BSP	½	Spare
3	BSP	½	Sensor pocket
4	BSP	2	Inlet
5	BSP	2¼	Immersion heater boss
6	BSP	2	Outlet
7	BSP	¾	T&P valve
8	BSP	1	Coil connection
10		N/A	Dual thermostat
11	BSP	N/A	Plugged Drain

Model	Volume	Coil size	Dimension	
			A	B
SIT600	575	54	740	1978
SIT900	840	81	1080	1600
SIT1100	1125	108	1080	2040
SIT1400	1380	108	1180	2074
SIT1900	1875	162	1380	2038
SIT2500	2500	162	1380	2595
SIT3000	3000	162	1380	3040

2.1.2 SDT600-3000

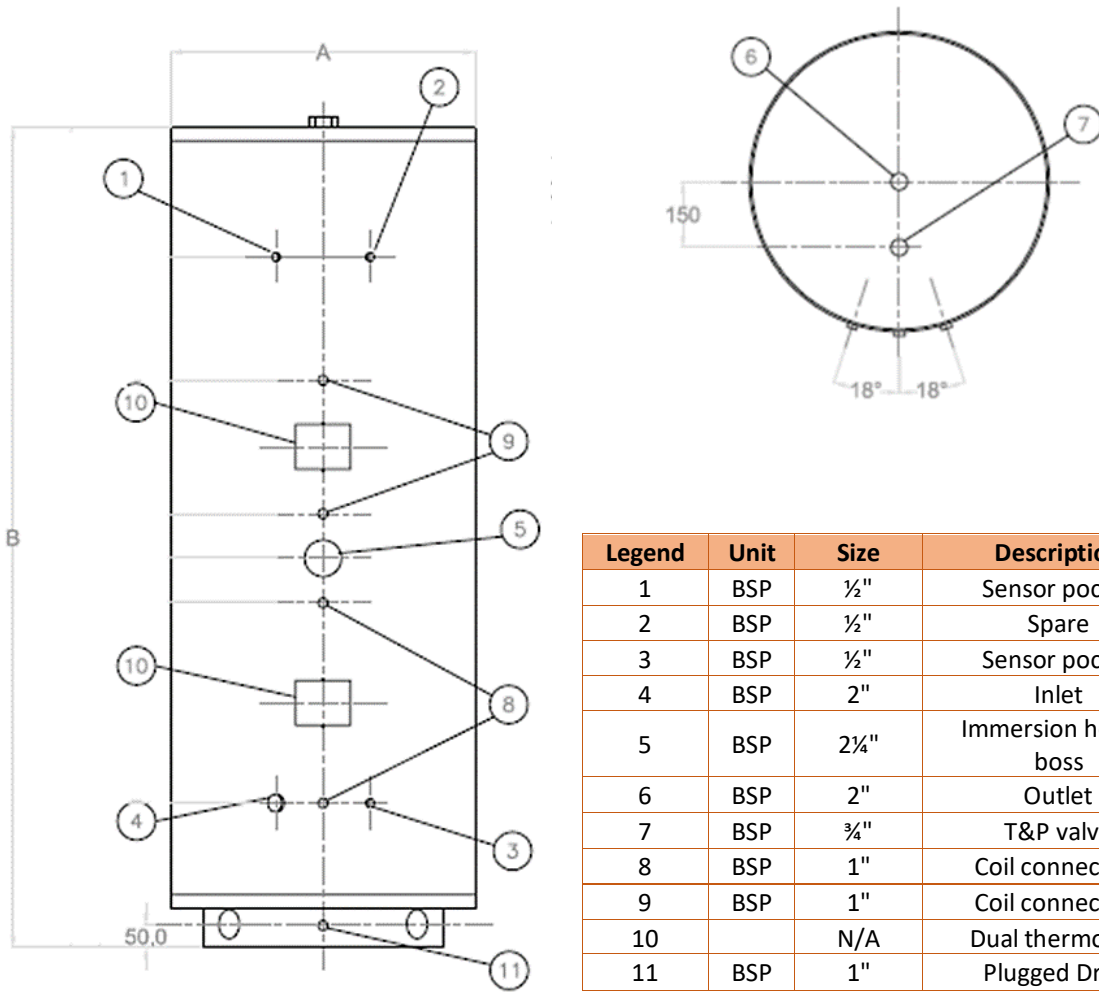

Model	Volume	Lower Coil size kW	Upper Coil size kW	Dimension	
				A	B
SDT600	575	27	27	740	1978
SDT900	840	27	40	1080	1595
SDT1100	1125	54	40	1080	2100
SDT1400	1380	54	54	1180	2120
SDT1900	1875	81	67	1380	2050
SDT2500	2500	81	81	1380	2600
SDT3000	3000	81	67	1380	3040

### 3.0 GENERAL REQUIREMENTS

The Lochinvar Squire stainless steel vessel has been designed to operate trouble free for many years. These instructions should be followed closely to obtain the maximum usage and efficiency of the equipment. **PLEASE** read the instructions fully before installing or using the appliance.

#### 3.1 RELATED DOCUMENTS

The installation should follow the relevant guidance offered in the following documents. It is not practical to list all relevant information but emphasis is placed on the following documents, as failure to comply with the guidance given will almost certainly result in an unsatisfactory installation:

- |                                  |  |
|----------------------------------|--|
| <b>BS 6700: 1997</b>             | Design, installation, testing and maintenance of services supplying water for domestic use within buildings and their curtilages |
| <b>BS 7074: 1989<br/>1 and 2</b> | Application, selection and installation of expansion vessels and ancillary equipment for <b>Parts</b> sealed systems             |
| <b>BS 7671: 2008</b>             | Requirements for electrical installations, I.E.E. wiring regulations seventeenth edition   |
| <b>CP 342:<br/>Part 2 1974</b>   | Code of practice for centralised hot water supply-buildings other than dwellings   |

#### 4.0 WATER QUALITY

Water supply quality may adversely affect the efficiency performance and longevity of Water Heaters and Hot Water systems. Hard water may cause the formation of limescale which will reduce operating efficiency and may cause early product failure. Please note the following: -

- Water Hardness – should not exceed 205ppm CaCO<sub>3</sub> and Total Dissolved Solids (TDS) of should not exceed 350ppm.  
**If these values are exceeded a water treatment specialist should be consulted. Water Softeners and Water Conditioners may be considered, but whichever method is selected, it should be suitable for installation with Squire stainless indirect Water Heaters. A maintenance regime will also be required for such systems.**
- High hot water temperature and high demand for hot water is likely to cause quicker limescale formation.



**The formation of limescale or other solids can cause a blockage within the heat exchanger, which in turn may cause premature failure. Such instances are not regarded as defects in manufacture and will not be covered under the product warranty**



## 5.0 WATER CONNECTIONS

### 5.1 GENERAL

1. Circulating pipe work should be insulated; cisterns, expansion vessels and pipe work situated in areas exposed to freezing conditions should also be insulated.
2. Drain valves must be located in accessible positions that will permit draining of the entire system.
3. Ideally, individual valves should be fitted to each unit to enable isolation from the system.

### 5.2 UN-VENTED SYSTEM



**It is the law that unvented hot water systems be installed by an approved installer.**

If the Lochinvar Squire stainless steel vessel is to be used in an unvented arrangement the system should follow the guidance given in **BS6700** and must comply with **The Building Regulations: Part G3 in England and Wales, P5 in Northern Ireland and P3 in Scotland**. A kit of components that have been suitably sized for the unvented or boosted operation of the appliance is available from Lochinvar Limited.

If you require a pipe work schematic for multiple appliance/storage vessel combinations, please contact Lochinvar Limited.

Safety must be provided on indirectly heater systems were the energy input must be restricted by control and/or other means. On unvented hot water systems were the heat source is from the primary circuit of a boiler, a two port motorised valve and high limit stat must be fitted which causes the valve to close to cut off the energy source.



**Lochinvar Ltd reserves the right to change specifications without prior notice. All necessary additional valves and fittings to be determined by those other than Lochinvar Ltd. Lochinvar Ltd may provide technical advice and guidance to assist with best practice, optimisation and installation of Lochinvar products; however, we will not be liable for any duties as Designers under Construction (Design and Management Regulations 2015). In all cases where information is provided, the customer must assess and manage risks associated with the technical information and advice provided.**

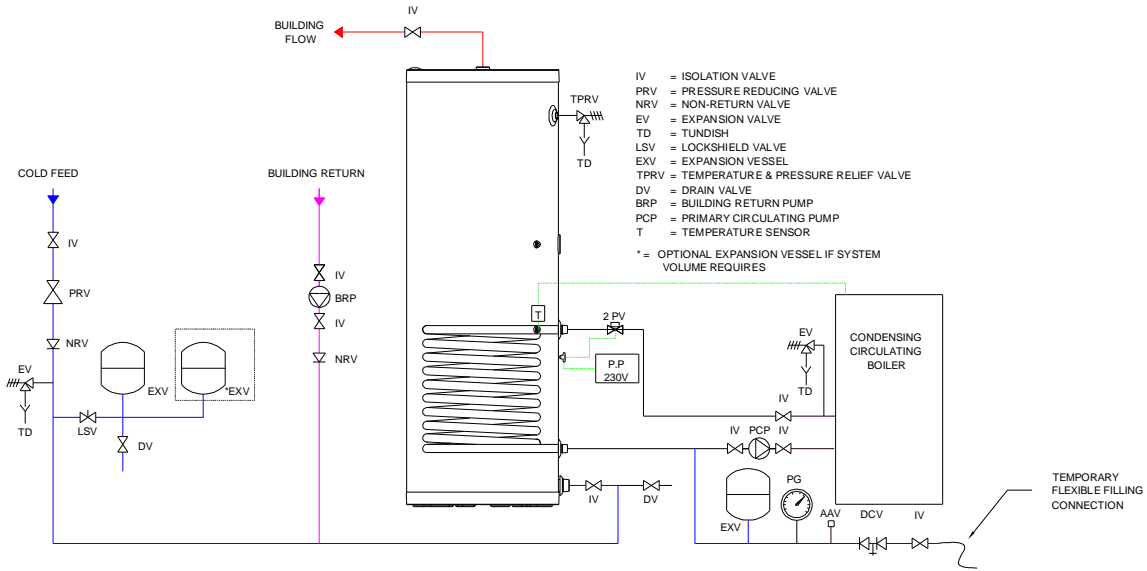

**5.2.1 TYPICAL SCHEMATIC SIT INDIRECT WATER HEATER WITH BOILER**

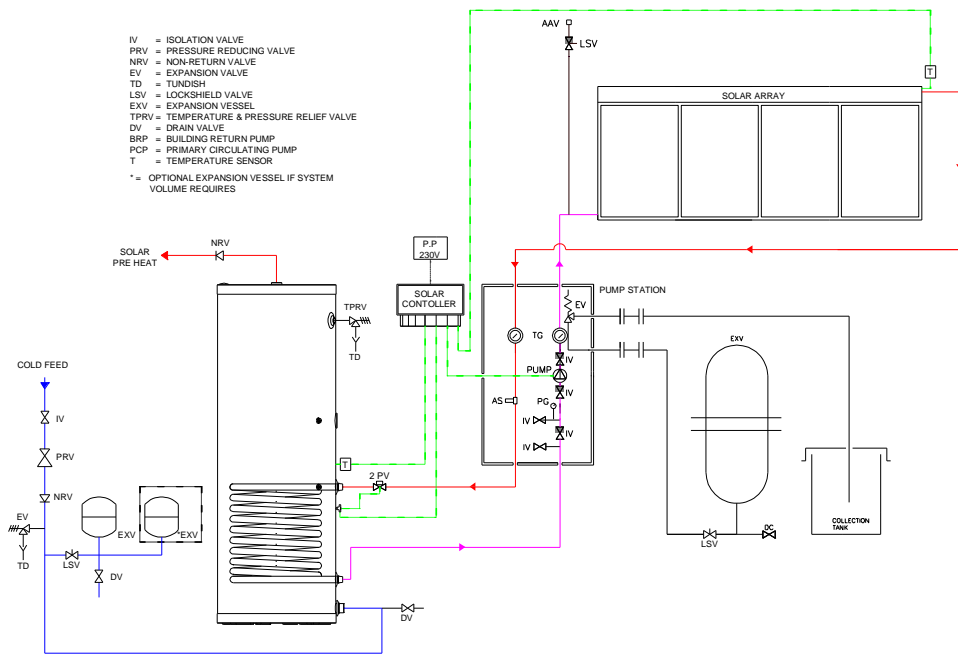

**5.2.2 TYPICAL SCHEMATIC SIT INDIRECT WATER HEATER USED AS A SOLAR PRE-HEAT**

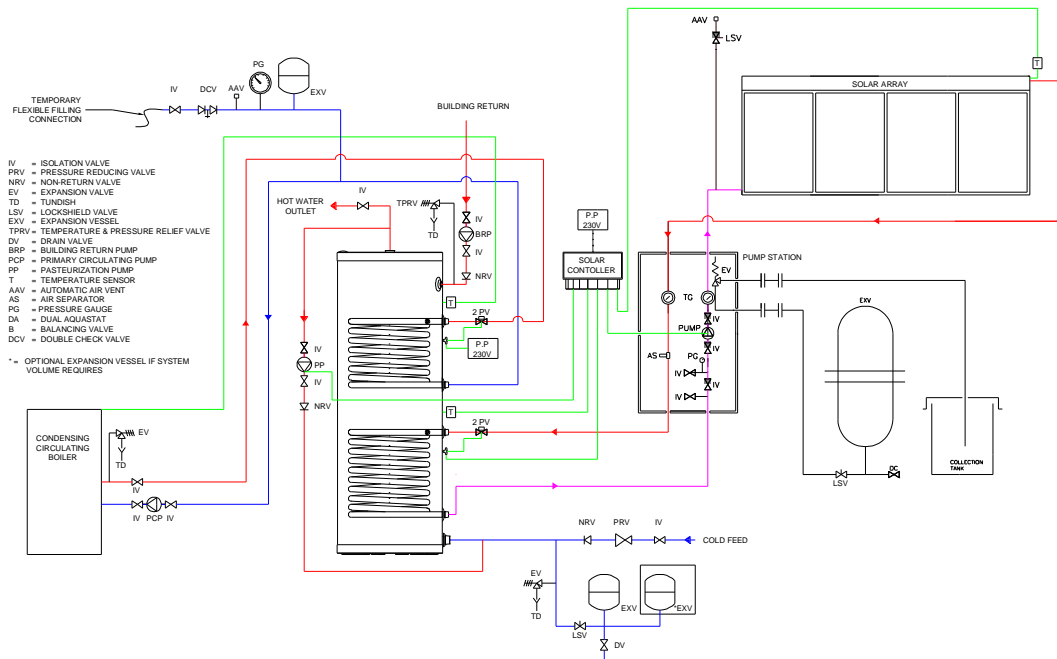

**5.2.1** TYPICAL SCHEMATIC SDT INDIRECT WATER HEATER USED AS A SOLAR PRE-HEAT WITH BOILER

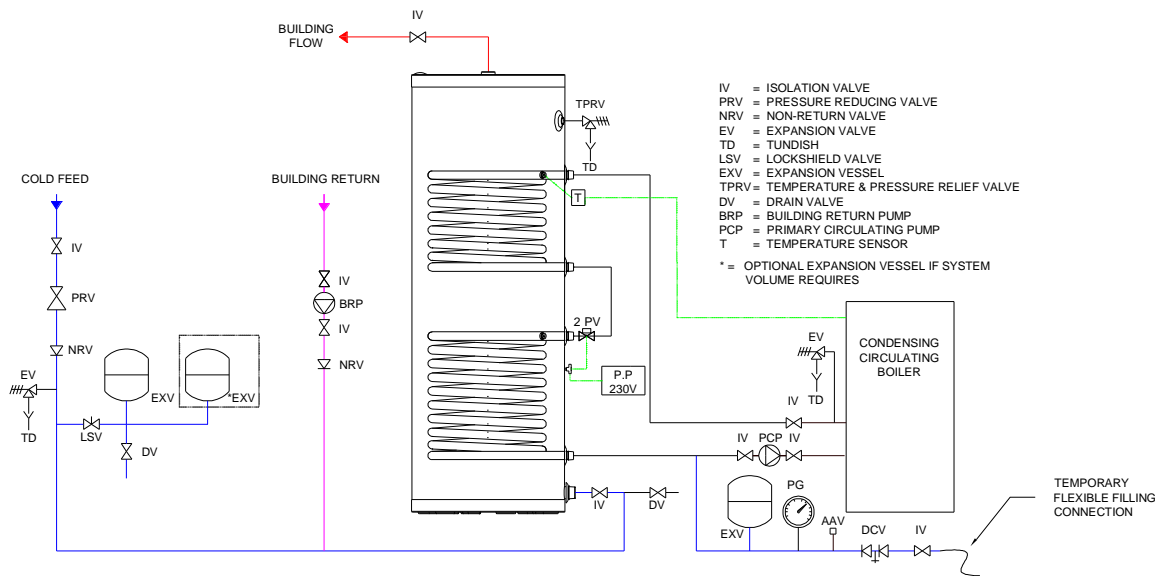

**5.2.2** TYPICAL SCHEMATIC SDT INDIRECT WATER HEATER WITH BOILER UTILISING BOTH COILS FOR FASTER RECOVERY

### 5.2.3 TEMPERATURE AND PRESSURE RELIEF VALVE

A temperature and pressure relief valve is provided in the unvented water system kit. This valve has a lift pressure of 7 bar and a lift temperature of 90°C. The valve must be fitted to the relief valve tapping located on the front of the appliance.



**The storage vessel relief valve connection should not be used for any other purpose.**

### 5.2.4 RELIEF VALVE DISCHARGE PIPEWORK

It is important that any discharge water does not collect in the discharge pipe-work and can run freely to the tundish. The tundish should be mounted in a vertical and visible position located in the same space as the unvented hot water storage system and be fitted as close as possible and within 600mm of the safety device e.g. the temperature relief valve.

The discharge pipe from the tundish should terminate in a safe place where there is no risk to persons in the vicinity of the discharge, be of metal or other material that has been demonstrated to be capable of safely withstanding temperatures of the water discharged and is clearly and permanently marked to identify the product and performance standard, and:

- a) Be at least one pipe size larger than the nominal outlet size of the safety device unless its total equivalent hydraulic resistance exceeds that of a straight pipe 9m long i.e. discharge pipes between 9m and 18m equivalent resistance length should be at least two sizes larger than the nominal outlet size of the safety device, between 18 and 27m at least 3 sizes larger, and so on. Bends must be taken into account in calculating the flow resistance.

An alternative approach for sizing discharge pipes would be to follow BS6700 Specification for design installation, testing and maintenance of services supplying water for domestic use within buildings and their curtilages.

- b) Have a vertical section of pipe at least 300mm long, below the tundish before any elbows or bends in the pipe work.
- c) Be installed with a continuous fall of at least 1 in 200.
- d) Have discharges visible at both the tundish and the final point of discharge but where this is not possible or is practically difficult there should be clear visibility at one or other of these locations.

Examples of acceptable discharge arrangements are:

- I. Ideally below the fixed grating and above the water seal in a trapped gulley.
- II. Downward discharges at a low level; i.e. up to 100mm above external surfaces such as car parks, hard standings, grassed areas etc. are acceptable providing that where children play or otherwise come into contact with discharges, a wire cage or similar guard is positioned to prevent contact whilst maintaining visibility.
- III. Discharges at a high level; e.g. into a metal hopper and metal down pipe with the end of the discharge pipe clearly visible (tundish visible or not) or onto a roof capable of withstanding high temperature discharges of water and 3m from any plastic guttering systems that would collect such discharges (tundish visible).
- IV. Where a single pipe serves a number of discharges, such as in blocks of flats, the number served should be limited to not more than 6 systems so that any installation can be traced reasonably easily. The single common discharge pipe should be at least one pipe size larger than the largest individual discharge pipe to be connected. If unvented hot water storage systems are installed where discharges from safety devices may not be apparent i.e. in dwellings occupied by blind, infirm or disabled people, consideration should be given to the installation of an electronically operated device to warn when discharge takes place.

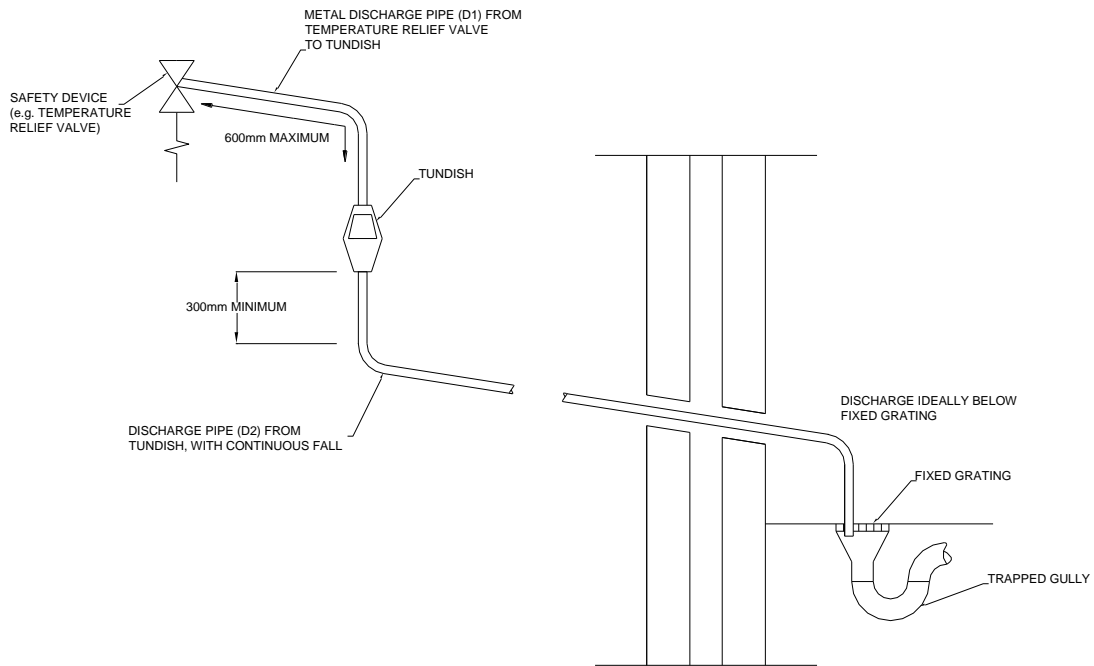

### 5.2.5 RELIEF VALVE DISCHARGE PIPEWORK

### 5.2.6 EXPANSION VESSEL SIZING

The following information is based on an inlet pressure of 3.5 bar. If a different inlet pressure is to be used, please consult **BS6700**.

$$V V = \frac{S V * e}{0.45}$$

Where:

- V V = Vessel Volume
- S V = System Volume
- e = Coefficient of Expansion (See Table Below)

Stored Temp.	°C	30	35	40	45	50	55	60
e		0.005	0.006	0.008	0.01	0.012	0.015	0.017
Stored Temp.	°C	65	70	75	80	82	85	90
e		0.02	0.023	0.026	0.03	0.031	0.033	0.037

### 5.2.7 COEFFICIENT OF EXPANSION OF WATER AT 3.5 BAR INLET PRESSURE

### 5.2.8 SOLAR EXPANSION VESSEL SIZING

Any solar expansion vessels should be sized, installed and commissioned as per solar instructions.

## 5.3 DE-STRATIFICATION

### 5.3.1 GENERAL

The De-stratification Pump Kit works by using a pump to circulate water from the top of the vessel to the bottom of the vessel. This action ensures that the water held in the unit is maintained at a consistent temperature throughout. By achieving a uniformed stored water temperature of at least 60°C, the risk of any bacterial contamination is virtually eliminated.

Systems that have a building loop incorporated onto the vessel may not require a de-stratification kit, provided the circulation around the building from the top of the vessel returns back to the bottom. This should provide sufficient mixing.

### 5.3.2 REQUIREMENTS

Lochinvar has developed this kit to meet the stringent recommendations of both the HSE Approved Code of Practice L8 and Department of Health Memorandum HTM 04-01 relating to the control of legionella within solar thermal installations.

## 6.0 COMMISSIONING AND TESTING

### 6.1 ELECTRICAL INSTALLATION

Any ancillary item that requires an electrical supply should be installed and commissioned as per instructions.

### 6.2 WATER CONNECTION

For design see **Section 5: Water connections.**



**The system should be thoroughly flushed out with cold water without any circulating pumps in position. Ensure all the valves are open.**

If a building return pump is to be fitted, it should be fitted before the system is filled and air locks cleared. Check the system for leaks and repair as necessary. If the system is configured in an unvented arrangement, check the expansion vessel cushion pressure.

### 6.3 PRIMARY HEAT SOURCE

The primary heat source operating in conjunction with the indirect water heater should be installed and commissioned in accordance with the relevant ICM Instructions provided.

## **7.0 MAINTENANCE**

### **7.1 GENERAL**

Regular servicing is recommended, preferably by a Lochinvar appointed person, to ensure trouble free operation. Even if a maintenance schedule is determined to be less than annually, it is important that all controls and safety features are checked for correct operation on an annual basis.

### **7.2 DRAINING THE WATER SYSTEM**

Maintenance and service procedures for the Squire may require draining the water heater. The water heater must also be drained if it is to be shut down and exposed to freezing temperatures.

1. Turn off the water heater if applicable.
2. Connect a hose to the system drain valve.
3. Locate hose's discharge in an area where hot water will not cause any damage or injury.
4. Close the cold-water inlet valve to water heater system.
5. Open a nearby hot water outlet to vent the system.
6. Open the drain valve.
7. If the vessel is being drained for an extended shutdown, it is suggested the drain valve be left open during this period.

### **7.3 RE-FILLING THE SYSTEM**

1. Close the drain valve.
2. Open a hot water fixture to allow air to escape.
3. Open the cold water supply to water heater and allow the vessel to fill.
4. Check for water leakage.

### **7.4 OTHER CHECKS**

#### **7.4.1 RELIEF VALVE**

At least once a year, the temperature and pressure relief valve and safety valve should be checked to ensure that they are in operating condition. To check each valve, lift the lever or turn the screw cap at the end of the valve several times. The valve should operate freely and seat properly.

If water does not flow, remove and inspect for obstructions or corrosion. Replace with a new valve of the recommended size as necessary.

## 8.0 USER INSTRUCTIONS

Your Squire Stainless unvented hot water cylinder has been designed to give many years of trouble free service and is made from hygienic, high grade stainless steel. Where applicable, it includes a 3kW electric immersion heater which heats the water to 60°C once pre-heating of the solar system is completed (SIT models for Solar use only).

The flow temperature of the hot water can be set to your requirements on the immersion heater (ideally 60°C maximum). Higher temperatures can cause tripping of the high limit thermostat and introduce more energy loss from the cylinder. When a hot tap is turned on there may be a short surge of water, this is quite normal with unvented systems and does not mean there is a fault.

When you first fill a basin the water may sometimes appear milky. This is due to very tiny air bubbles in the water which will clear very quickly.



**Warning: if cold/warm water exits from the temperature and pressure relief valve (TPV) or from the pressure relief valve (PRV) call your installer. If very hot water exits from either valve switch off the heat source immediately and isolate the electricity supply to the cylinder and separate heat source.**



**The solar system is configured to heat the water to its maximum economic temperature which may vary with ambient temperature and weather conditions. The immersion may be programmed to operate during fixed periods of the day or night.**



**If the hot water runs cool it may be necessary to manually switch on the immersion to heat the water – please see the relevant instructions for your alternative energy device.**

## 9.0 WARRANTY

See warranty terms and conditions document available at [www.lochinvar.ltd.uk](http://www.lochinvar.ltd.uk)



10.0 APPENDIX 1 TECHNICAL DATA TABLES SIT600-3000

	Unit	SIT600	SIT900	SIT1100	SIT1400	SIT1900	SIT2500	SIT3000
Storage Capacity	litres	575	840	1125	1380	1875	2500	3000
<b>EFFICIENCY DATA-Part L2</b>								
Insulation Thickness	mm	50	90	90	90	90	90	90
Insulation Type								
Standing Loss	kWh/ltr/day	0.005	0.004	0.003	0.003	0.002	0.002	0.002
<b>GENERAL DATA</b>								
Max draw off capacity (first hour) at 50°C temperature rise	l/hr	1390	2067	2759	2963	4289	4789	5189
Heat-up Time at 50°C temperature rise	min	37	36	36	45	40	54	65
Dimensions (height with insulation )	mm	1978	1600	2100	2120	2050	2600	3040
Dimensions (diameter with insulation)	mm	740	990	990	1090	1290	1290	1290
Weight (empty)	kg	114	162	195	241	291	370	427
Weight (full)	kg	689	1002	1320	1621	2166	2870	3427
Minimum Working Pressure	bar	0.5	0.5	0.5	0.5	0.5	0.5	0.5
Maximum Working Pressure	bar	6	6	6	6	6	6	6
Hot Outlet Connection (inches)	BSP	2	2	2	2	2	2	2
Cold Feed Connection (inches)	BSP	2	2	2	2	2	2	2
Coil Connection (inches)	BSP	1	1	1	1	1½	1½	1½
<b>COIL DATA</b>								
Coil Rating (80/60°C)	kW	54	81	108	108	162	162	162
Coil Surface Area	m <sup>2</sup>	2	3	4	4	6	6	6
Flow Rate (80/60°C)	l/sec	0.45	0.4	0.35	0.35	1.45	1.45	1.45
Pressure Loss	kPa	30	30	30	30	30	30	30
Maximum Coil Temperature	°C	110	110	110	110	110	110	110
Maximum Coil Pressure	bar	6	6	6	6	6	6	6

11.0 APPENDIX 2 TECHNICAL DATA TABLES SDT600-3000

	Unit	SDT600	SDT900	SDT1100	SDT1400	SDT1900	SDT2500	SDT3000
Storage Capacity	litres	575	840	1125	1380	1875	2500	3000
<b>EFFICIENCY DATA-Part L2</b>								
Insulation Thickness	mm	50	90	90	90	90	90	90
Insulation Type								
Standing Loss	kWh/ltr/day	2.88	3.29	3.6	3.84	4.13	4.56	4.87
<b>GENERAL DATA</b>								
Max draw off capacity (first hour) at 50°C temperature rise Top coil	l/hr	924	1360	1588	2033	2652	3393	3552
Heat-up Time at 50°C temperature rise Top coil	min	50	37	59	54	49	65	104
Dimensions (height with insulation )	mm	740	1080	1080	1180	1380	1380	1380
Dimensions (diameter with insulation)	mm	1978	1595	2100	2120	2050	2600	3040
Weight (empty)	kg	114	162	195	241	291	370	427
Weight (full)	kg	689	1002	1320	1621	2166	2870	3427
Minimum Working Pressure	bar	0.5	0.5	0.5	0.5	0.5	0.5	0.5
Maximum Working Pressure	bar	6	6	6	6	6	6	6
Hot Outlet Connection (inches)	BSP	2	2	2	2	2	2	2
Cold Feed Connection (inches)	BSP	2	2	2	2	2	2	2
Coil Connection (inches)	BSP	1	1	1	1	1	1	1
<b>COIL DATA</b>								
Coil Output (80/60 °C) Bottom/Top	kW	27/27	27/40	54/40	54/54	81/67	81/81	81/67
Coil Surface Area Bottom/Top	m <sup>2</sup>	1.0/1.0	1.0/1.5	2/1.5	2.0/2.0	3.0/2.5	3.0/3.0	3.0/2.5
Flow Rate (80/60 °C) Bottom/Top	l/sec	0.33/0.33	0.33/0.495	0.45/0.495	0.45/0.45	0.4/0.43	0.4/0.4	0.4/0.43
Pressure Loss Bottom/Top	kPa	12.2/12.2	12.2/14.3	30/14.3	30/30	30/30	30/30	30/30
Maximum Coil Temperature	°C	110	110	110	110	110	110	110
Maximum Coil Pressure	bar	6	6	6	6	6	6	6

## 12.0 APPENDIX 3 ErP SPECIFICATION DATA SHEETS

Information	Unit	Lochinvar Limited				
Trade mark	-	Lochinvar Limited				
Model Identifier	-	SIT600	SIT900	SIT1100	SIT1400	SIT1900
Energy efficiency class	-	N/A	N/A	N/A	N/A	N/A
Standing loss	W	120	137	150	160	172
Storage volume	litres	575	840	1125	1380	1875

Information	Unit	Lochinvar Limited				
Trade mark	-	Lochinvar Limited				
Model Identifier	-	SDT600	SDT900	SDT1100	SDT1400	SDT1900
Energy efficiency class	-	N/A	N/A	N/A	N/A	N/A
Standing loss	W	120	137	150	160	172
Storage volume	litres	575	840	1125	1380	1875



8 Lombard Way, The MXL Centre, Banbury, Oxon, OX16 4TJ  
Tel: +44(0) 1295 269 981, Fax: +44(0) 1295 271 640, Email: [info@lochinvar.ltd.uk](mailto:info@lochinvar.ltd.uk)  
[www.lochinvar.ltd.uk](http://www.lochinvar.ltd.uk)